



## Investigation of Deposits in Urea-SCR After-Treatment Systems for Heavy-Duty Diesel Engines

JIYUAN ZHANG<sup>1,2</sup>, SHAOJUN SUN<sup>2</sup>, YIBAO WANG<sup>2</sup>, JIANZHONG TAO<sup>2</sup> and GUOXIANG LI<sup>1,\*</sup>

<sup>1</sup>School of Energy and Power Engineering, Shandong University, Jinan 250061, P.R. China

<sup>2</sup>Center of Research and Department, WEICHAI Power Co. Ltd., Weifang 261001, P.R. China

\*Corresponding author: Fax: +86 531 88392701; Tel: +86 531 88395623; E-mail: [liguox\\_baishzh@163.com](mailto:liguox_baishzh@163.com)

(Received: 3 February 2012;

Accepted: 12 December 2012)

AJC-12532

To ensure SCR system normal application, one of the basic requirements is to avoid the deposition of urea droplets including crystallization in the exhaust stream. Design and calibration principles are the main causes of urea deposition. Unreasonable structure design, machining and installation can lead to urea crystallization phenomenon inside the bore of the nozzle, on the exhaust pipe wall and the front end surface of the catalyst because of the insufficient atomization and decomposition of urea droplets. In addition, unreasonable calibration strategy can also deteriorate this condition. The components of the urea deposits were tested and analyzed by thermo-gravimetry-FTIR technology indicating that the urea deposits are the urea and cyanuric acid. On this basis, the modified structure of integral nozzle mounting is provided to improve the design. The engine dynamometer test and the vehicle road test were conducted showing that the optimal design and calibration strategy can effectively avoid crystallization and sedimentation in the system.

**Key Words:** Urea-SCR, Crystallization and sedimentation, Urea deposition, Structural optimization, Calibration strategy.

### INTRODUCTION

Urea-SCR technology is the main means for heavy-duty diesel engines to meet the emission standards of CN IV and CN V<sup>1,2</sup>, using 32.5 % urea solution, matching with the optimal combustion, so that it can reduce the emission of NO<sub>x</sub> and effectively decrease the fuel consumption. With increasingly stringent emission regulations, Urea-SCR technology on vehicle diesel has been more widely used. However, one problem that threatens the life and performance of the urea SCR system is urea deposits *e.g.*, the crystallization and urea deposits, *etc.* Because the SCR system has complicated physical and chemical reaction, including the atomization, breakup and evaporation of the urea droplets, the energy and momentum exchange between the droplets and the exhaust, the collision process of particle, the formation of the liquid film, the catalytic reduction of NO<sub>x</sub> and the atomization and the temperature after the urea's injection vary with the condition of the diesel engine, the urea droplets decompose into the ammonia, at the same time, they produce intermediate products (by products), such as cyanic acid, biuret, cyanuric acid, which cause the urea crystallization and deposition<sup>3-5</sup>. The sediments progressively accumulate, creating concerns of backpressure and material deteriorations. In addition, deposits as a waste of reagents can negatively affect engine operation and emissions performance. Gao Junhua<sup>6</sup>, Lifeng Xu *et al.*<sup>7</sup>, analyze the urea sediments

using the following equipment, such as gas phase chromatography mass spectrum linking, infrared spectrum, nuclear magnetic resonance, thermo gravimetric mass spectrum linking. Guanyu Zheng<sup>8</sup> illustrate the influence of the SCR system layouts, the different exhaust pipe wall temperatures and the multiple urea mixers on the urea deposits by engine dyno test. In addition, Gabriel Salanta<sup>9</sup> published a study on the effect of entirely urea SCR system layout to urea-related deposits by both CFD analysis and engine dyno test.

The urea deposition phenomenon was researched in the development and application process of SCR system and provides improvement measures and design solutions which base on the analysis of the formation conditions for the urea crystallization and other deposition. This study not only analyzes the urea crystallization and sedimentation phenomenon and constituents, but also explores proprietary methods to decrease the urea sediments and provides the theoretical evidences to optimize the urea injection control strategy and reference for the design of the SCR system.

**Analysis of the urea crystallization and sedimentation phenomenon:** Urea depositions frequently were found in several location of downstream *e.g.*, between the nozzle and the injector connection boss, the injection housing and the inner surface of the exhaust pipe.

**Urea crystallization and sedimentation phenomenon on the nozzle:** Fig. 1 illustrates the urea crystallization and

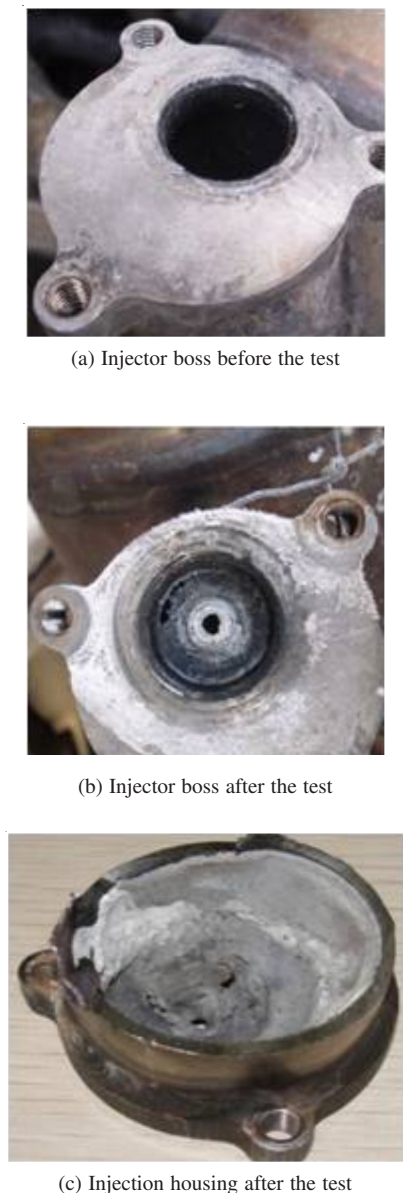
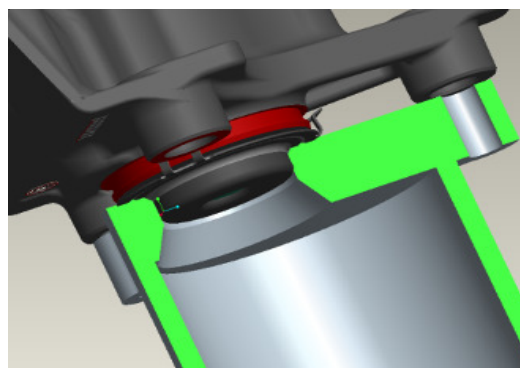

Fig. 1. Urea crystallization and deposition on injection housing

sedimentation phenomenon on the nozzle in the test. The result shows that the crystallization and deposition located near the hole of the injector mounting base and eventually blocked the injection housing.

Fig. 2 illustrates the assembling of the nozzle and the flow inside the hole of the holder. It shows that the local vortex cavity after the urea injection point. A portion of injected droplets swirl with the air flow inside the sleeve of the holder instead of going down sufficiently with the exhaust gas, finally deposited near to the nozzle slits and became dry urea, when heated, the water evaporates, the urea precipitated and became crystal. The accumulated crystal took up the atomization space of the urea droplets, which destroyed the normal atomization process, so that the conversion of the NO<sub>x</sub> in the system reduced. When it is worse, the urea droplets flow from the crystal in the state of the liquid, the water evaporate when heated, with the injection time increased, the accumulation rate of the crystal rises and eventually block the passage of the injector connection boss.



(a) Assembling of the nozzle in injector mounting base

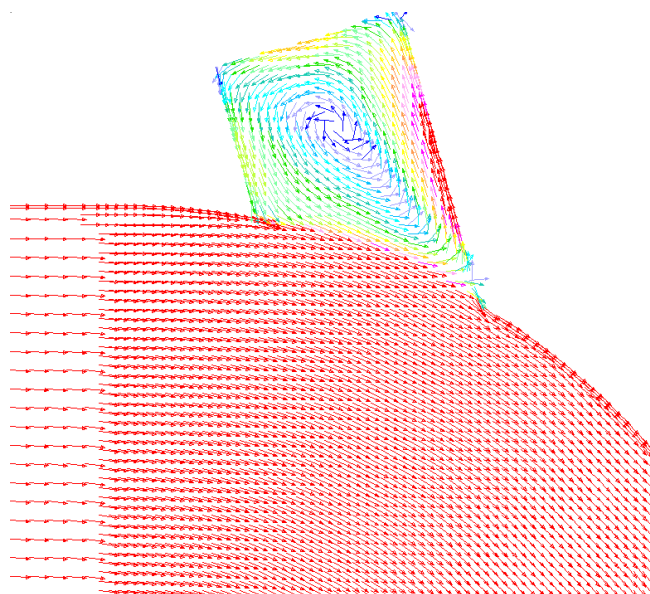

(b) Swirl flow in injector mounting base

Fig. 2. Urea crystallization and deposition phenomenon on the nozzle

**Urea crystallization and deposition phenomenon under the injector mounting base:** Fig. 3(a) shows the urea crystallization and sedimentation phenomenon under the injector mounting base. It shows that plenty of white sediments gathered under the injector mounting base. These sediments can't be eliminated by heating, proving that they have been sedimentation phenomenon. The main reasons are the unreasonable arrangement of the urea injector mounting base at the exhaust pipe and the long connecting sleeve. As shown in Fig. 3(b), the narrow space can't meet the atomization requirement of the urea droplets, which causes the urea droplets can't inject on the wall, after the water evaporated, the crystal precipitated and became the sedimentation phenomenon. The continually accumulation and deposition blocked the exhaust pipe. The more welding sludge inside the injector boss the easier of the urea droplets to form crystallization and deposition.

**Urea crystallization and sedimentation phenomenon in the exhaust pipes:** The urea crystallization and sedimentation phenomenon in the exhaust pipes is given in Fig. 4. The deviation of the fixing angle for the injector mounting base in the exhaust pipe makes it easier to inject the urea on the wall of the exhaust pipe. In the real exhaust system, because the exhaust temperature is relatively low under certain load and the diameter of the exhaust pipe is smaller, when the droplets



(a) Bottom of the injector mounting base

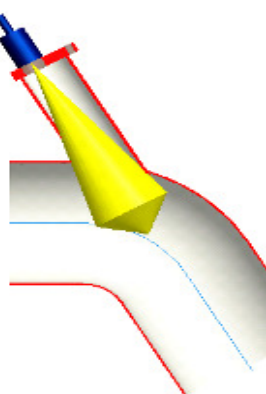

(b) Illustration for the collision of the urea droplets

Fig. 3. Urea crystallization and deposition phenomenon under the injector mounting base



Fig. 4. Urea crystallization and sedimentation phenomenon on the inner wall of the exhaust pipe

inevitably splashed onto the wall, the liquid film will form and the crystallization and sedimentation will deposit. The evaporation of the liquid film will decrease the temperature of the pipe wall, which increases the formation of the crystal.

In conclusion, the reasons for the urea crystallization and sedimentation are mainly as follows: Firstly, because of the unreasonable layout, the urea droplets became dry urea; the heated water evaporated and formed the crystal. Secondly, because of the fault of the injection system, the urea solution are badly atomized. The urea droplets retain on the exhaust pipe wall, which causes the crystallization. Or the bigger droplets can't be sufficiently decomposed on the surface of the catalyst and causes the crystallization.

Thirdly, the low loads of the engine results in the low exhaust temperature. If the ambient temperature is low, the

temperature of the exhaust pipe wall is low, so that the injected urea is hard to decompose and cause the crystallization on the inner wall of the exhaust pipe.

**Components analysis of the urea crystallization and sedimentation:** The urea crystallization and sedimentation were taken from the injector boss, the lower end of the injector mounting base and the exhaust pipe. The constituents were analyzed by means of the TGA-FTIR.

**Thermogravimetric analysis of the urea deposition:** This study compares the thermogravimetric analysis between the sampled urea deposition and the pure urea. The rising rate of the temperature is 10 °C/min. The comparison of the urea deposition at different position and the thermogravimetric analysis of the pure urea are shown in Fig. 5, *ca.* 90 % depositions have been decomposed when the temperature rises to 410 °C. The thermolysis process of the deposition at the urea nozzle position is the same as the deposition at the lower end of the injector mounting base, showing that the components are the same. The quality of the urea deposition begins to gradually decrease at 190 °C and substantially reduce to 350 °C. The quality drops to 10 % of the original quality at 420 °C, 5 % at 500 °C and 1.5 % at 700 °C, after which it remains the same.

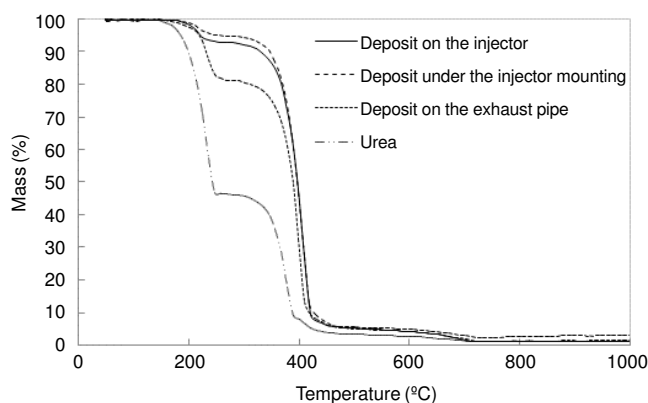
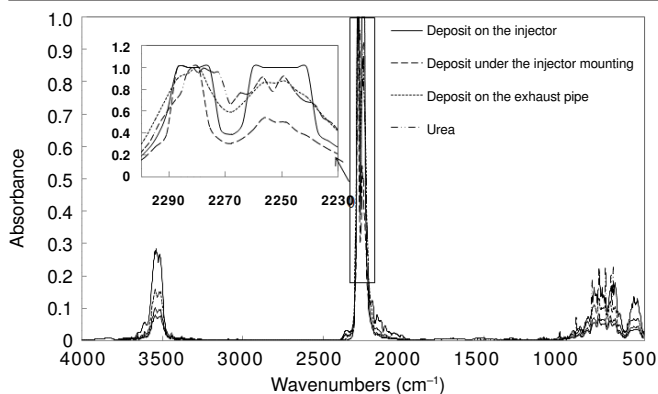

Fig. 5. Comparison of the thermolysis process among the depositions and the urea

The thermolysis proves the urea deposition inside the exhaust pipe is similar to the pure urea from 220-245 °C, showing that the components contain some urea. The thermolysis process is similar to the above-mentioned positions over 245 °C, showing that the main components of the urea deposition from the three different positions are the same.

**Infrared spectra analysis to the thermolysis decompositions of the urea deposition:** The decomposition yields of the sampled urea deposition and the pure urea were analyzed using the thermogravimetric analysis process and the infrared spectra, comparing with the standard infrared absorption spectra of the ammonia and the isocyanic acid (Fig 6). There is only one peak during the thermolysis process of the urea depositions from three positions and two peaks of the absorption spectrum during the thermolysis process of the urea. The peak spectral absorption map of the decomposition yields of the deposition is similar to that of the isocyanic acid, so the main thermolysis yields of deposition is the isocyanic acid. The peak spectral absorption map of the decomposition

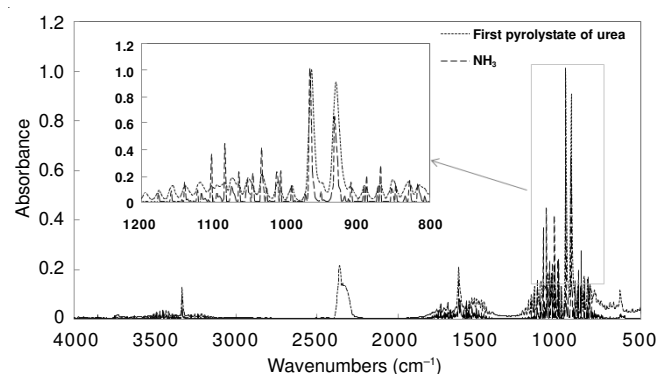
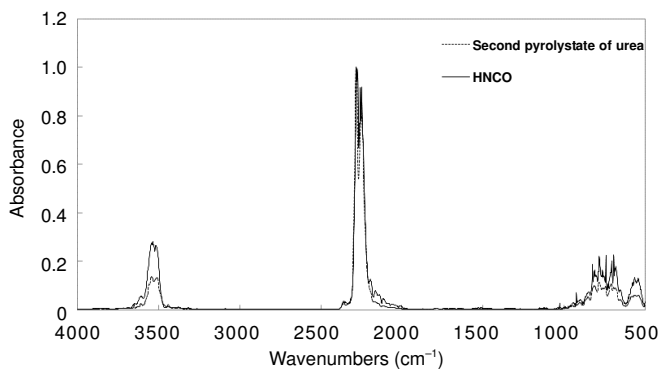

(a) Comparison of deposits and HNCO

(b) Comparison of first pyrolysate of urea and NH<sub>3</sub>

(c) Comparison of second pyrolysate of urea and HNCO

Fig. 6. Comparison of the infrared absorption spectrum

products of the urea is similar to those of the ammonia and the isocyanic acid, so that we can infer the main thermolysis products of urea, respectively are the ammonia and the isocyanic acid, but the first yields is the ammonia.

TGA-FTIR shows the main yields of the urea deposition are the ammonia gas and the isocyanic acid and the main yields of the urea is the ammonia gas. Ammonia gas obtained from urea and the isocyanic acid was produced from cyanuric acid when heated more than 350 °C. So the main component of crystallization and deposition is solid urea and cyanuric acid.

**Yields analysis of the urea deposition:** Fourthly, there is a serial of chemical reaction from urea to NH<sub>3</sub><sup>10</sup>, as shown in Fig. 7, producing several byproducts such as biuret, cyanuric acid *etc.* The crystallization of urea, which is on the exhaust pipe or the surface of catalyst, can produce biuret, cyanuric

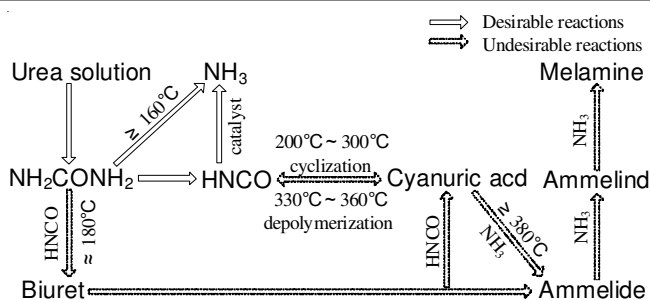
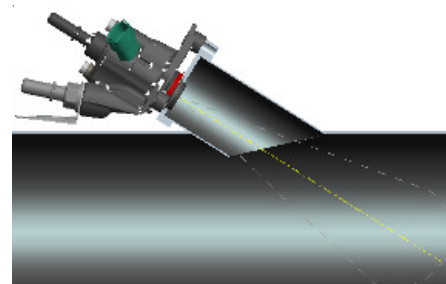

Fig. 7. Reactions involved in urea thermolysis

acid even melamine by condensation reaction, named as deposition. However the deposition can be decomposed at high temperature. But if decomposing speed and temperature is not high enough, the deposition can still be get worse.

### Solutions and the improvement of the design

**Improvement of the structural design:** Fig. 8(a) shows the linkage of the urea nozzle in the SCR system. There are two problems in the integral nozzle mountings which fix the urea injector boss onto the exhaust pipe by welding procedure: (1) the welding housing needs the long bulge wall of the injector mounting base, which results in urea solution spray to the inner surface of the injection mounting base and facilitates the urea crystallization and deposition; (2) the limitation of the injector mounting base sleeve structure results in the urea crystallization and sedimentation (Fig. 8).



(a) Assembled injector mountings

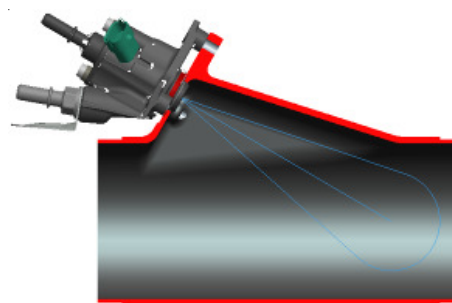

(b) Integral injector mountings

Fig. 8. Layout of the injector mountings

The problems can be solved providing the integral design of the injector mounting base mentioned above, as shown in Fig. 8(b). The injection housings of the linking section facilitate the atomization of the urea. Besides, the slope design between the end face of the injector boss and the fixing pipe enables the outer edge of the injection cone angle to parallel to the whole wall of the injector mounting base. This design can

avoid the urea droplets to splash onto the linking pipe wall as much as possible.

Fig. 9 is the analogy calculation result of the integral injector mounting base. It shows that the integral injector mounting base can effectively prevent the accumulation of the urea deposition around the nozzle and reduce the crystallization and sedimentation of the urea solution at the urea injector mounting base.

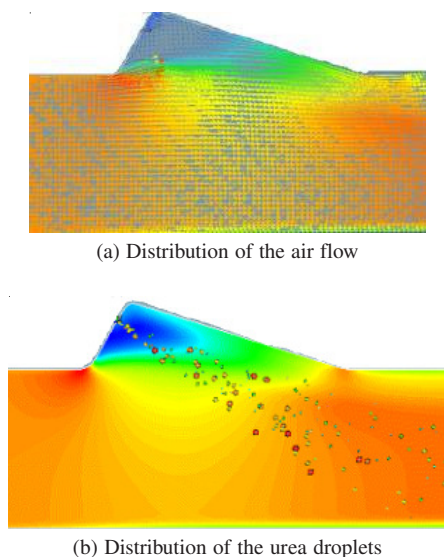

Fig. 9. Results of the CFD calculation

**Calibration strategy of the urea injection:** Unreasonable calibration strategy is one of the reasons for urea deposits. Urea spray rate is calculated by the  $\text{NO}_x$  and the NSR strategies. The impact of the exhaust temperature is another consideration. The lower the exhaust temperature was, the slower the decomposition rate was. Both the lower initial temperature and higher injection amount at low exhaust temperature will accelerate crystallization and deposition inside the exhaust pipe and on the surface of the catalyst. The NSR calibration based on the exhaust temperature is very important. And the internal combustion of engine and the character of SCR should be considered. The calibration strategy not only meet the performance of the engine, but offer a better catalytic result in desired temperature window to avoid the urea deposits. Reasonable initial temperature setup and optimal injection calibration strategy are the main means to solve the problem.

#### Verification of the test

**Integral injector mountings with welding art:** The primary reliability test of 200 h is to verify the influence of the structure to the prevention of the urea crystallization and sedimentation and found no deposition of them. The engine dynamometer test is given in Fig. 10.

#### Calibration principle of the urea injection

**Impact of the exhaust temperature on the urea deposition:** The engine pedestal test which researched the influence of the exhaust temperature on the urea deposition was carried out. The test conditions were as follows: the exhaust speed is 20 m/s, the injection rate of the urea is 8.33 g/min, the exhaust temperatures are 203, 227, 245 and 272 °C separately.



Fig. 10. Engine Dyno test setup

The result of the test is as shown in Fig. 11, it shows that the higher the exhaust temperature was, the smaller the generation of the deposition. When the temperature rises to 272 °C, there will be no urea deposition.

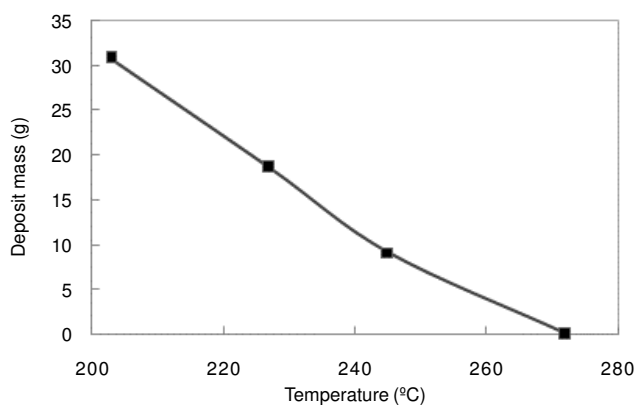

Fig. 11. Influence of the exhaust temperature on the generation of the urea deposition

**Influence of the urea injection rate on the urea deposition:** The engine dynamometer test which researched the influence of the urea injection rate on the urea deposition at the same exhaust temperature and flow rate was carried out. The test conditions were as follows: the exhaust speed is 20 m/s, the exhaust temperatures are 227 and 245 °C, the injection rate of the urea is 8.33 and 5 g/min. The result of the test is shown in Fig. 12, it shows that the urea solution injection rate has a great influence on the urea deposition. When the injection rate drops from 8.33-5 g/min, there will be no urea deposition.

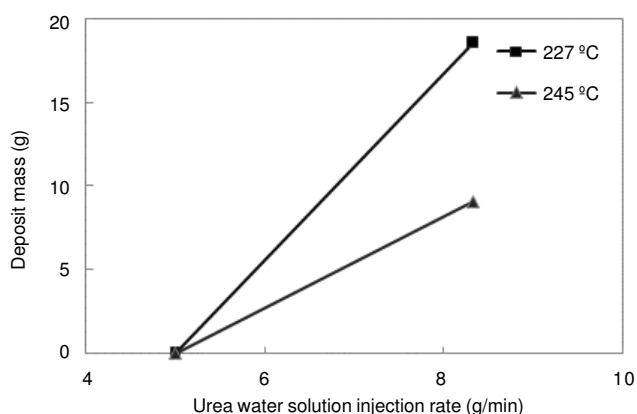

Fig. 12. Impact of the urea solution injection rate on the urea deposition at different exhaust temperatures

### Conclusion

Verification experiments have been conducted showing that the optimized pipe layout and calibration principles effectively prevent the formation of urea crystallization and other deposition. The conclusions are as follows: TGA-FTIR shows the urea and the pyrolytic acid are the main components of the urea crystallization and deposition which can be almost eliminated if heated to 500 °C. The structure of integral injector mountings can prevent the urea crystallization and deposition. The optimized calibration principles of the urea injection, including the increase of the injection initial temperature and the correction of the urea injection amount, can effectively reduce the urea deposition.

### ACKNOWLEDGEMENTS

This study was supported by a grant from the National Science Foundation of China (No. 51035001) and the authors would like to thank the reviewers whose constructive and detailed critique contributed to the quality of this paper.

### REFERENCES

1. T.V. Johnson, Review of Diesel Emissions and Control, SAE paper, 01-0301 (2010).
2. T. Jianzhong, Study on DeNOx Technology by Selective Catalytic Reduction (SCR) for Heavy-Duty Diesel Engines, Jinan:Shandong University (2008).
3. V.O. Strots, S. Santhanam, B.J. Adelman, G.A. Griffin and E.M. Derybowski, Deposit Formation in Urea-SCR Systems, SAE paper, 2009-01-2780 (2009).
4. K. Hirata, N. Masaki and H. Ueno, Development of Urea-SCR System for Heavy-Duty Commercial Vehicles, SAE paper, 01-1860 (2005).
5. Y. Zhu, S. Zhou, M. Liu and J. Wang, *Asian J. Chem.*, **24**, 5519 (2012).
6. J.-H. Gao, J. Kuang, C.-L. Song, Z.-R. Zhang and X.-J. Jing, *J. Combust. Sci. Technol.*, **16**, 547 (2010).
7. L. Xu, W. Watkins, R. Snow, G. Graham, R. McCabe, C. Lambert and R.O. Carter, Laboratory and Engine Study of Urea-Related Deposits in Diesel Urea-SCR After-Treatment Systems, SAE Paper 01-1582 (2007).
8. G. Zheng, A. Fila, A. Kotrba and R. Floyd, Investigation of Urea Deposits in Urea SCR Systems for Medium and Heavy Duty Trucks, SAE paper, 01-1941 (2010).
9. G. Salanta, G. Zheng, A. Kotrba, L. Bergantim and R. Rampazzo, Optimization of a Urea SCR System for On-highway Truck Applications, SAE paper, 01-0094 (2010).
10. P.M. Schaber, J. Colson, S. Higgins, D. Thielen, B. Anspach and J. Brauer, *Thermochim. Acta*, **424**, 131 (2004).